

Ultra-Flo® S-Version



Hollow Fibre Ultrafiltration Membrane

Ultra-Flo® is a hollow-fibre based membrane filtration product. This filtration process covers the ultrafiltration (UF) range of between 0.1 to 0.01 micron. It is designed to remove suspended particulates, colloidal material, bacteria and high molecular weight material.

This membrane will consistently produce high quality water effectively to meet your respective needs.

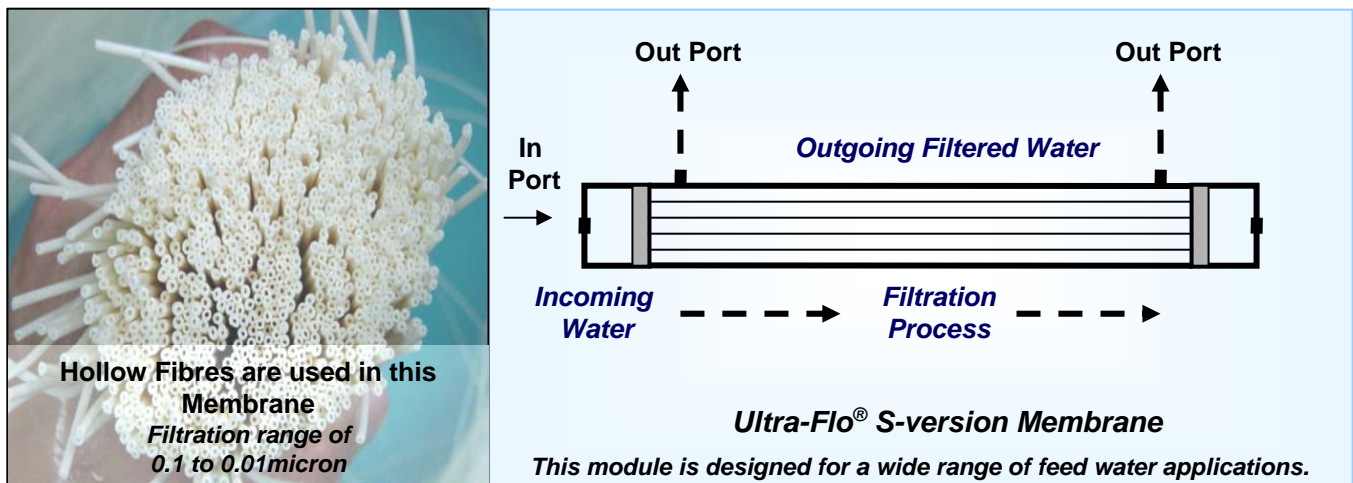

The Ultra-Flo® Membrane (S-version) can be used to apply to the following with its unique advantages :

Surface Water Clarification This membrane can be used to replace all conventional clarifying processes, eliminating the need for coagulant, flocculants, large clarifying tanks, media and sand filters. Without the need to use large clarifying tanks, one would conserve much valuable land. The system is neat and takes up very small footprint. A 500 m³/day UF system takes up only 2.4m x 1.2m of space. It is suitable for treating incoming piped water, all surface water such as reservoirs, lakes, rivers, canals, rain and bore-hole or underground water.

Waste Water Treatment In using the 'Ultra-Flo' membranes to replace conventional clarification processes, there is no need to use chemicals such as coagulant and flocculants. The membranes are made of hydrophilic modified Poly-Acrylo-Nitrile (PAN). Eliminating the use of chemicals will assist in further savings, particularly labour savings, as manpower is usually required in the accurate dosing of chemicals required in conventional water treatment plants.

RO Pre-Treatment The 'Ultra-Flo' Membrane is a ultrafiltration membrane which filters down to between 0.1 to 0.01 micron. It will remove all Total Suspended Solids (TSS) with more than 95% recovery, providing high quality feed water for Reverse Osmosis (RO) systems.



Ultra-Flo® S-Version

Hollow Fibre Ultrafiltration Membrane
S660, S630, S430



The permeate water is of high quality water that can be applied directly as RO feed water, high quality factory feed water, or residential supply water. This distinct advantage will out-perform any other sub-micron filtration product available in both cost and quality.

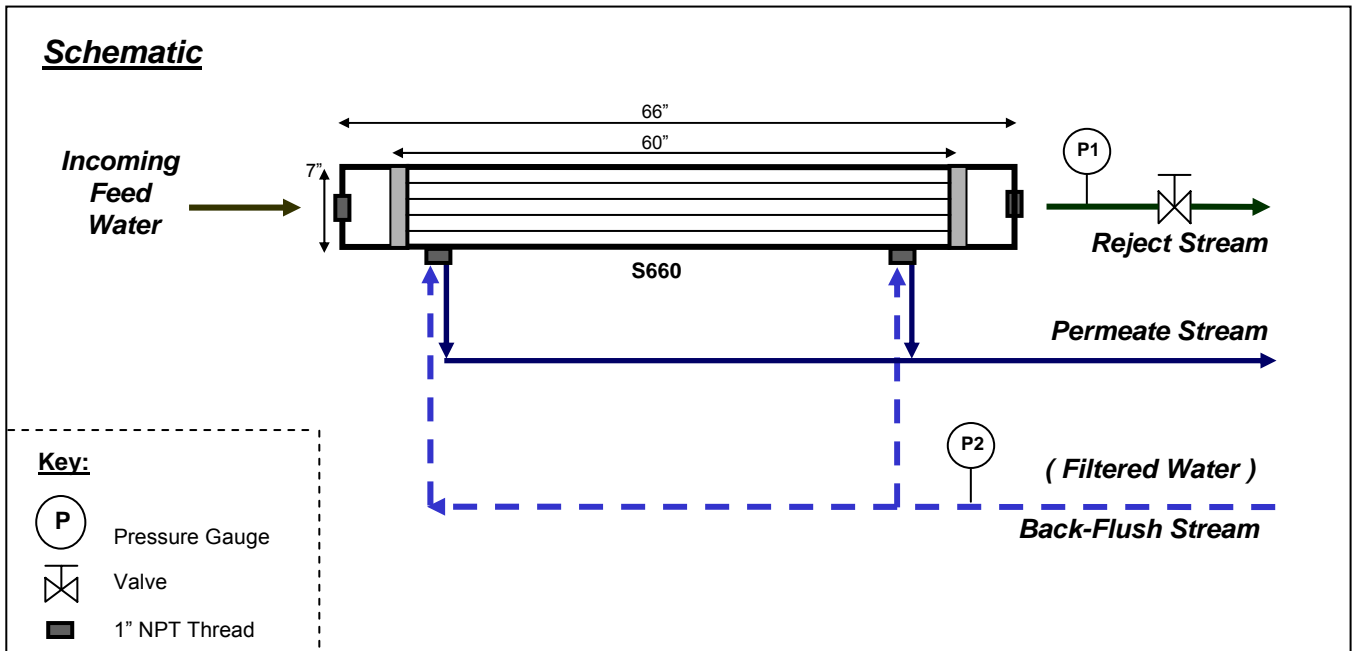

Operating Parameter

Configuration	: Capillary Type (In-to-Out)	Max Operating Pressure	: < 3 Bar
Material	: Hydrophilic Modified PAN	Operating Feed Pressure	: 0.5 Bar
Fibre Size	: OD 2.1mm, ID 1.2mm	Operating Back-flush Pressure	: < 1 Bar
pH range	: 2 – 12	Operating Temperature	: < 50° C
Recovery	: 95 %	Product Turbidity	: ≤ 0.1 NTU

<u>Model No</u>	<u>Product Flow at 1 Bar</u>	<u>Surface Area</u>	<u>Dimensions Ø x l</u>	<u>Weight</u>
S-660	1.0 – 1.5 m ³ /hr	28 m ²	6" x 60"	32 kg
S-630	0.6 – 0.8 m ³ /hr	12 m ²	6" x 30"	16 kg
S-430	~ 0.4 m ³ /hr	5 m ²	4" x 60"	11 kg

NB: Due to constant product upgrading and development, we reserve the right to change specifications from time to time.



Ultra-Flo® S660

Hollow Fibre Ultrafiltration Membrane



The 'Know-how' in Water Treatment

The permeate water is of high quality water that can be applied directly as RO feed water, high quality factory feed water, or residential supply water. This distinct advantage will out-perform any other sub-micron filtration product available in both cost and quality.

Operating Perimeter

Configuration	: Capillary Type (In-to-out)	Max Operating Pressure	: < 3 Bar
Material	: Hydrophilic Modified PAN	Operating Feed Pressure	: 0.5 Bar
Fibre Size	: OD 2.1mm, ID 1.2mm	Operating Temperature	: < 50° C
pH range	: 2 – 12	Feed Turbidity	: < 5 NTU
Housing Dimensions	: 7" x 66" (Ø x ℓ)	Product Turbidity	: Typically ≤ 0.1 NTU
Weight	: 32 kg	Product Flow (at 1 Bar)	: 1.0 – 1.5 m ³ /hr
Recovery	: 95 %	Surface Area	: 28 m ²

S660 Schematic

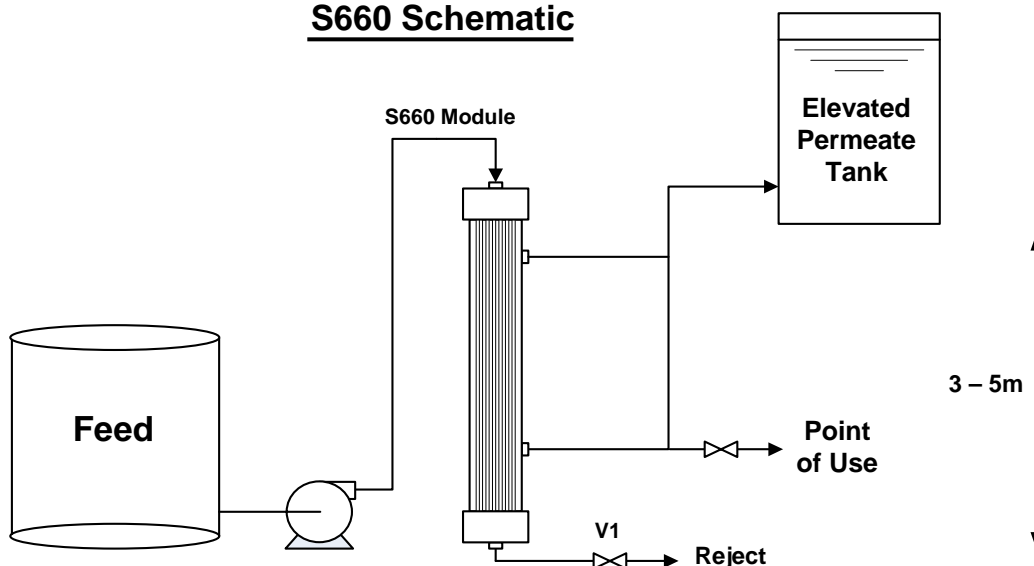

Precautions

- For first time start-up, throw away the first 20mins of permeate. Only use permeate after the first 20mins.
- If operation needs to be stopped for long periods i.e. more than a day, shut all ports to keep membrane wet.

S660 Operation

- 1) Start-up**
 - Open V1.
 - Start feed pump.
 - Shut V1. Throw away the first few minutes of permeate.
- 2) Cross-flow flushing (to wash the membrane from inside)**

This is required when permeate rate starts to drop.

 - While permeating, open V1.
 - This will allow some feed water to flush the membrane.
 - After 2 min, shut V1.
 - Continue with permeating.
- 3) Back-flush using permeate (to wash membrane from outside)**

This operation should be done at least once a day, at the end of the day or when the permeate rate drops drastically.

 - Stop the feed pump.
 - Ensure that there is at least 200 litres of water in the permeate tank.
 - Open V1.
 - Let the water flow out as reject.
- 4) Back-flush using chlorine (preferably once a week)**
 - Shut the feed pump and V1.
 - Fill the S660 with 100ppm of chlorine solution.
 - Leave overnight.



Ultra-Flo® S630

Hollow Fibre Ultra-Filtration Membrane



The 'Know-how' in Water Treatment

The permeate water is of high quality water that can be applied directly as RO feed water, high quality factory feed water, or residential supply water. This distinct advantage will out-perform any other sub-micron filtration product available in both cost and quality.

Operating Perimeter

Configuration	: Capillary Type (In-to-out)	Max Operating Pressure	: < 3 Bar
Material	: Hydrophilic Modified PAN	Operating Feed Pressure	: 0.5 Bar
Fibre Size	: OD 2.1mm, ID 1.2mm	Operating Temperature	: < 50° C
pH range	: 2 – 12	Feed Turbidity	: < 5 NTU
Housing Dimensions	: 7" x 36" (Ø x ℓ)	Product Turbidity	: Typically < 0.1 NTU
Weight	: 16 kg	Product Flow (at 1 Bar)	: 0.6 – 0.8 m ³ /hr
Recovery	: 95 %	Surface Area	: 12 m ²

S630 Schematic

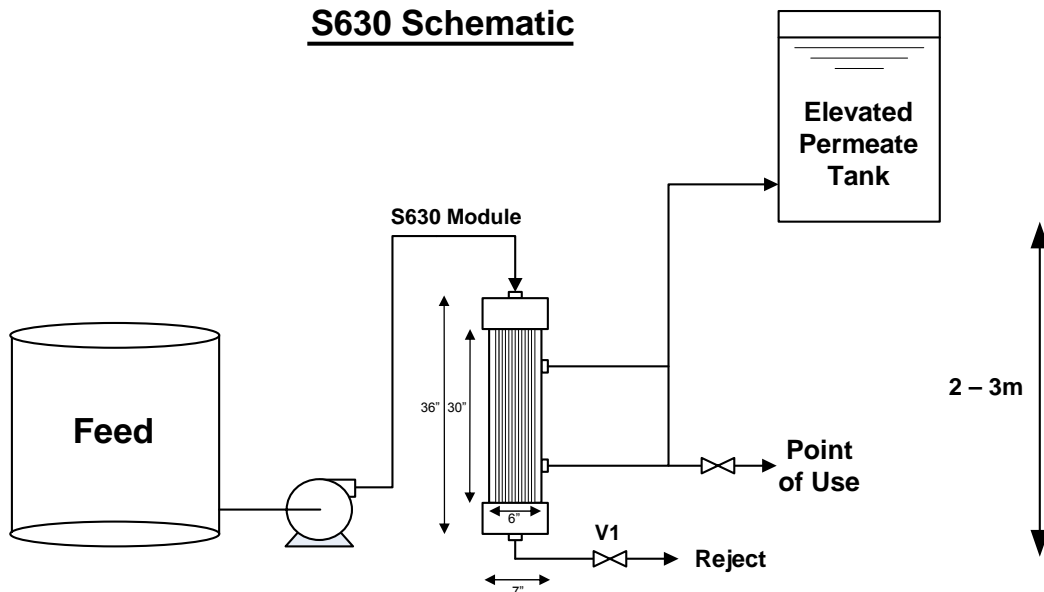

Precautions

- For first time start-up, throw away the first 20mins of permeate. Only use permeate after the first 20mins.
- If operation needs to be stopped for long periods i.e. more than a day, shut all ports to keep membrane wet.

S630 Operation

- Start-up**
 - Open V1.
 - Start feed pump.
 - Shut V1. Throw away the first few minutes of permeate.
- Cross-flow flushing (to wash the membrane from inside)**
This is required when permeate rate starts to drop.
 - While permeating, open V1.
 - This will allow some feed water to flush the membrane.
 - After 2 min, shut V1.
 - Continue with permeating.
- Back-flush using permeate (to wash membrane from outside)**
This operation should be done at least once a day, at the end of the day or when the permeate rate drops drastically.
 - Stop the feed pump.
 - Ensure that there is at least 200 litres of water in the permeate tank.
 - Open V1.
 - Let the water flow out as reject.
- Back-flush using chlorine (preferably once a week)**
 - Shut the feed pump and V1.
 - Fill the S630 with 100ppm of chlorine solution.
 - Leave overnight.

